

6

5

4

3

2

1

D

D

C

C

B

B

A

A

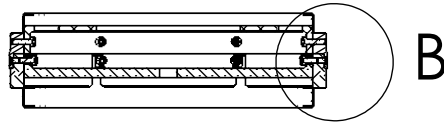
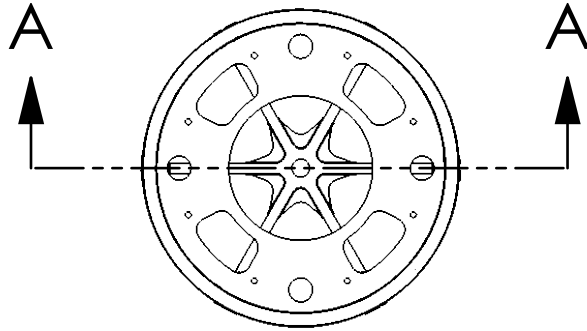

SECTION A-A

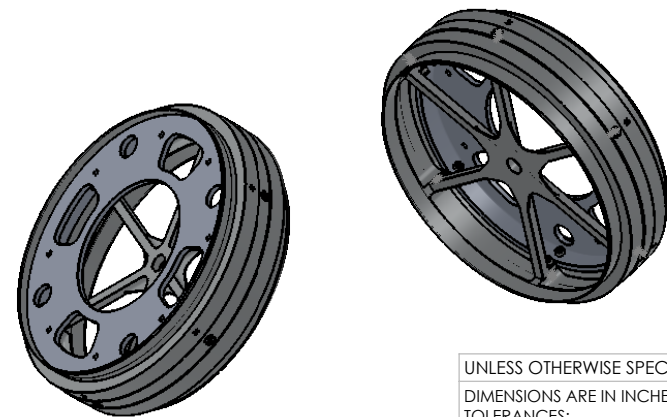
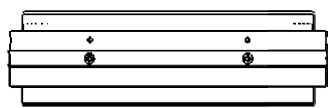

SOLIDWORKS Educational Product. For Instructional Use Only

UNLESS OTHERWISE SPECIFIED:
 DIMENSIONS ARE IN INCHES
 TOLERANCES:
 FRACTIONS: 1/32
 ANGULAR: MACH ± BEND ±
 TWO PLACE DECIMAL ±.01
 THREE PLACE DECIMAL ± .001

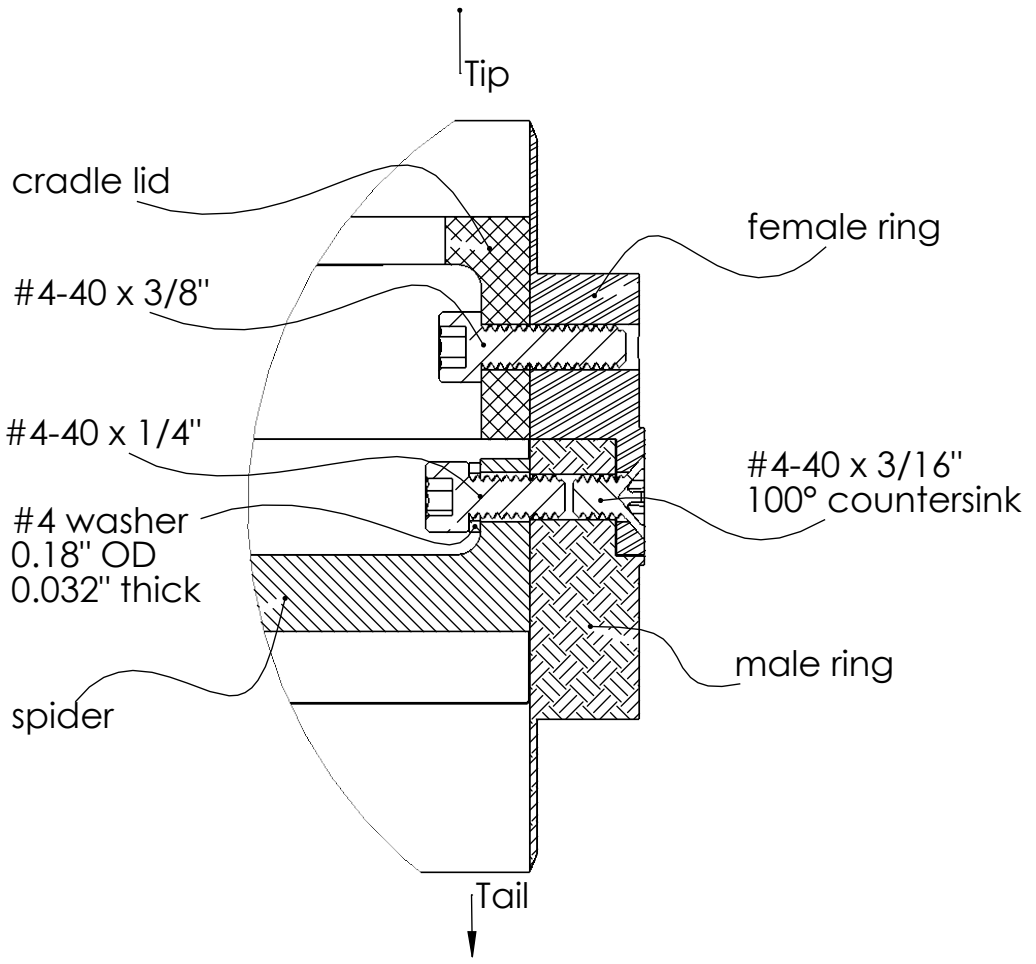

DETAIL B
 SCALE 2 : 1

	NAME	DATE	Description: Example of how internal subsystems mount to the LV3 airframe						
	DRAWN	Joe S. 2017-4-11							
	CHECKED	--							
	ENG APPR.	--							
	MFG APPR.	--							
MATERIAL			DWG. NO. --						
FINISH --									
Weight									
DO NOT SCALE DRAWING									
COMMENTS:			<table border="1"> <tr> <td>REV</td> <td>SIZE</td> <td>SCALE: 1:4</td> </tr> <tr> <td>i</td> <td>A</td> <td>SHEET 1 OF 1</td> </tr> </table>	REV	SIZE	SCALE: 1:4	i	A	SHEET 1 OF 1
REV	SIZE	SCALE: 1:4							
i	A	SHEET 1 OF 1							

6

5

4

3

2

1