

6 5 4 3 2 1

D

D

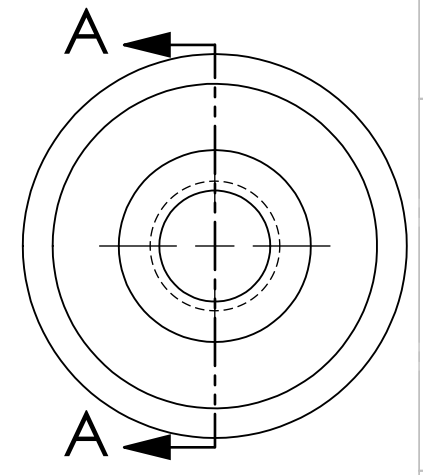
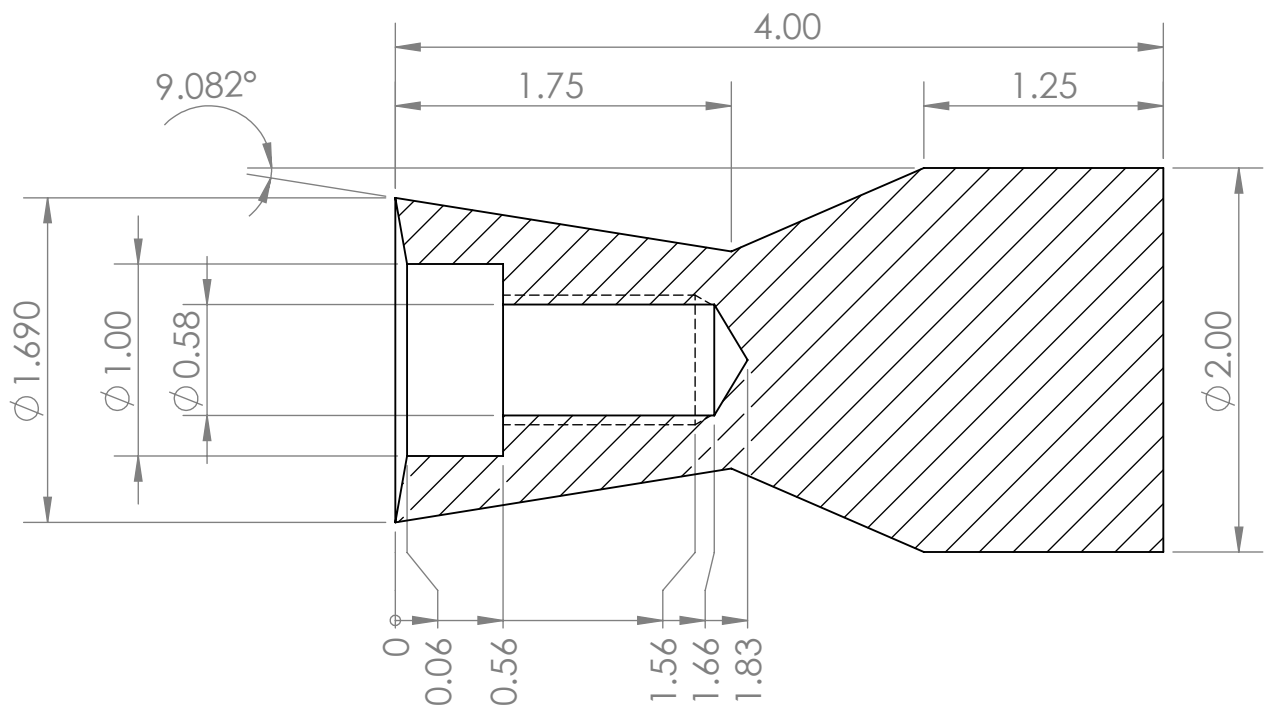

SECTION A-A

B

B

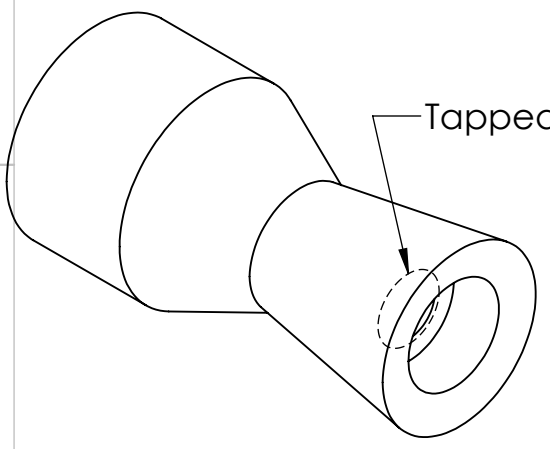

A

A

UNLESS OTHERWISE SPECIFIED:
 DIMENSIONS ARE IN INCHES
 TOLERANCES:
 FRACTIONAL ± 1/32
 ANGULAR: MACH ± BEND ±
 TWO PLACE DECIMAL ±.01
 THREE PLACE DECIMAL ± .001

	MATERIAL	6061-T6 aluminum
	FINISH	--
	Weight	
	DO NOT SCALE DRAWING	

	NAME	DATE
DRAWN	J. Shields	2017-5-22
CHECKED	--	
ENG APPR.	--	
MFG APPR.	--	

Description:
 A tool to help with the alignment of the nosecone plug

COMMENTS:

DWG. NO.		
--		
REV	SIZE	SCALE: 1:1
i	A	SHEET 1 OF 1

6 5 4 3 2 1