

6 5 4 3 2 1

D

D

C

C

B

B

A

A

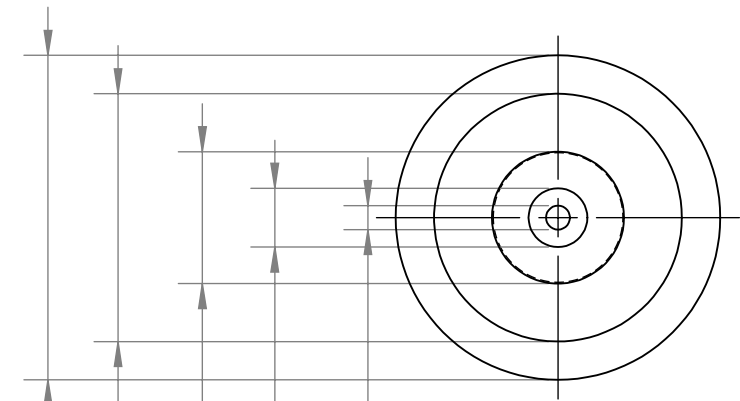
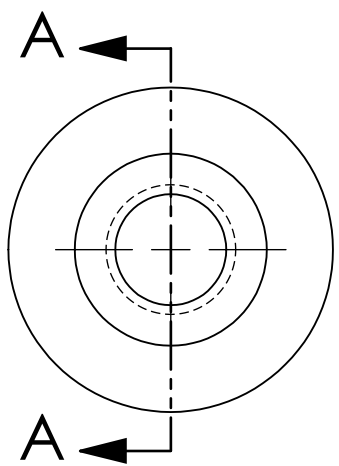

$\phi 1.69$
 $\phi 1.29$
 $\phi 0.69$
 $\phi 0.31$
 $\phi 0.12$

FRONT

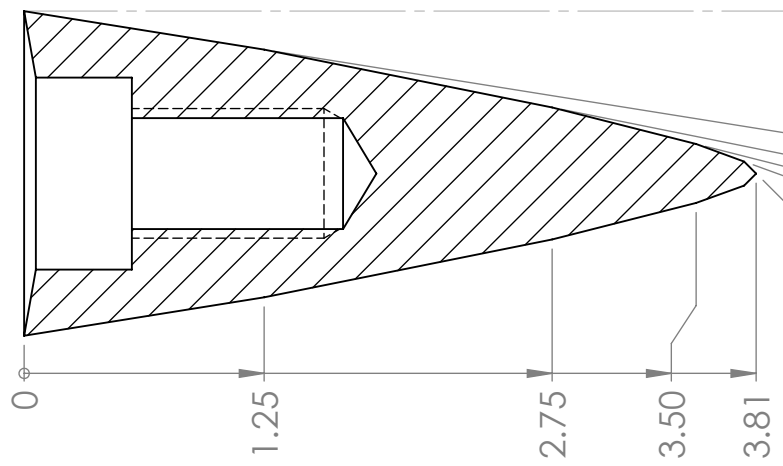

SECTION A-A

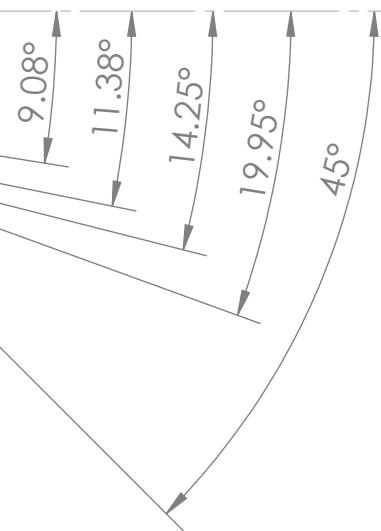

0 1.25 2.75 3.50 3.81

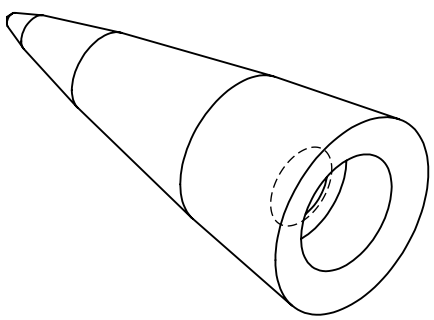

UNLESS OTHERWISE SPECIFIED:
 DIMENSIONS ARE IN INCHES
 TOLERANCES:
 FRACTIONAL $\pm 1/32$
 ANGULAR: MACH \pm BEND \pm
 TWO PLACE DECIMAL $\pm .01$
 THREE PLACE DECIMAL $\pm .001$

| | | |
|--|----------------------|------------------|
|  | MATERIAL | 6061-T6 aluminum |
| | FINISH | -- |
| | Weight | |
| | DO NOT SCALE DRAWING | |

| | NAME | DATE |
|-----------|------------|-----------|
| DRAWN | J. Shields | 2017-5-22 |
| CHECKED | -- | |
| ENG APPR. | -- | |
| MFG APPR. | -- | |

Description:
 A modification of the "dummy nose tip" to be made if a CNC nose tip can't be obtained

COMMENTS:
 Sorry for the insane dimensioning.

| | | |
|----------|----------|--------------|
| DWG. NO. | | |
| -- | | |
| REV | SIZE | SCALE: 1:1 |
| i | A | SHEET 1 OF 1 |

6 5 4 3 2 1