

6

5

4

3

2

1

D

D

C

C

B

B

A

A

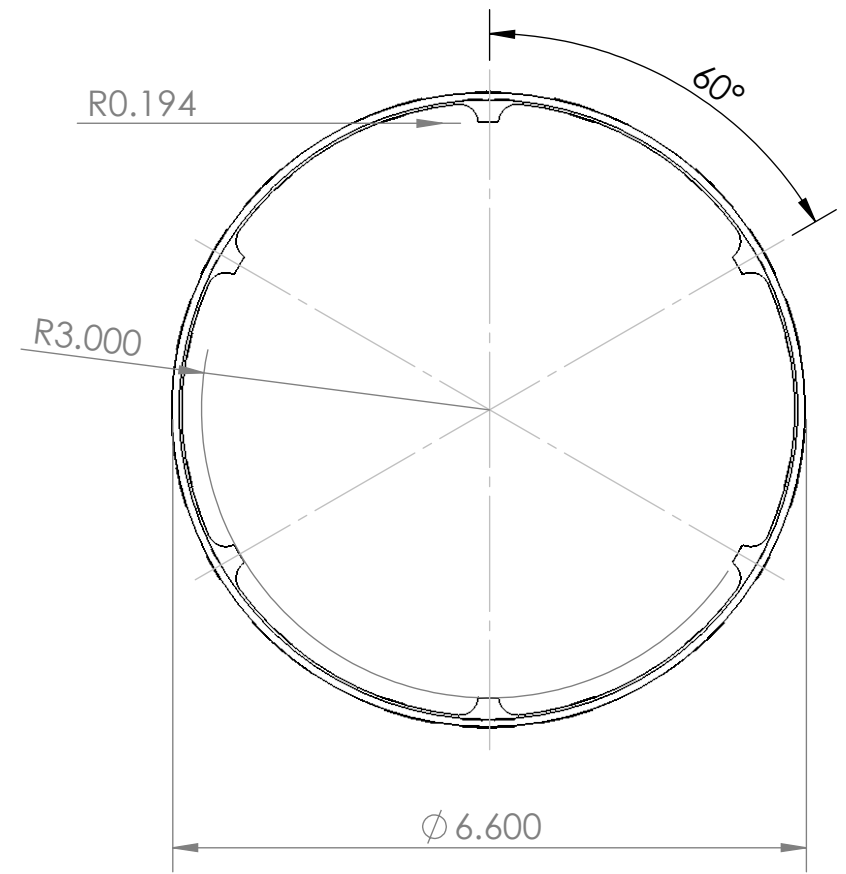
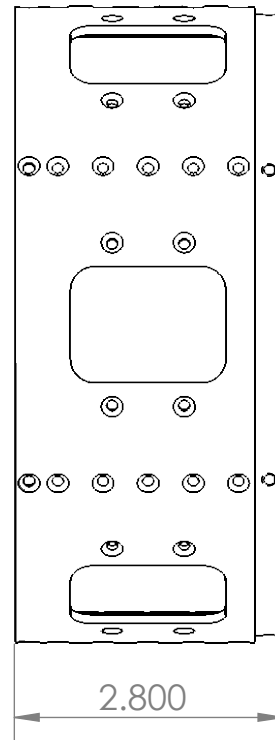
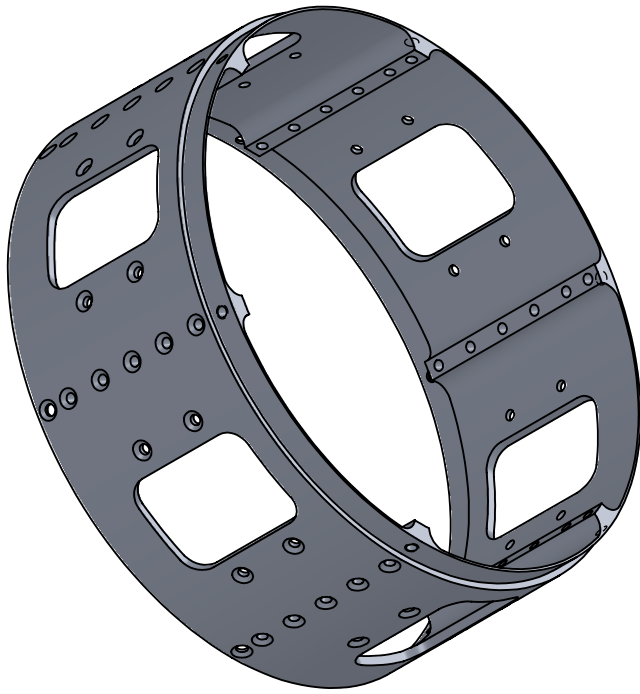

SOLIDWORKS Educational Product. For Instructional Use Only

UNLESS OTHERWISE SPECIFIED:
 DIMENSIONS ARE IN INCHES
 TOLERANCES:
 FRACTIONS 1/32
 ANGULAR: MACH ± BEND ±
 TWO PLACE DECIMAL ±.01
 THREE PLACE DECIMAL ± .001

	MATERIAL	6061-T6 aluminum
	FINISH	milled or bead-blasted
	Weight	
	DO NOT SCALE DRAWING	

	NAME	DATE
DRAWN	Joe S.	2/21/2018
CHECKED	--	
ENG APPR.	--	
MFG APPR.	--	

Description:
 ring structure for the LV3 camera and umbilical modules

COMMENTS:

DWG. NO.		--
REV	SIZE	SCALE: 1:2
v0.4	A	SHEET 1 OF 4

6

5

4

3

2

1

6

5

4

3

2

1

D

D

C

C

B

B

A

A

6X ϕ .120 ∇ 1.000
TAP FOR #4-40 HELICOIL INSERT = 1.0 * DIA.

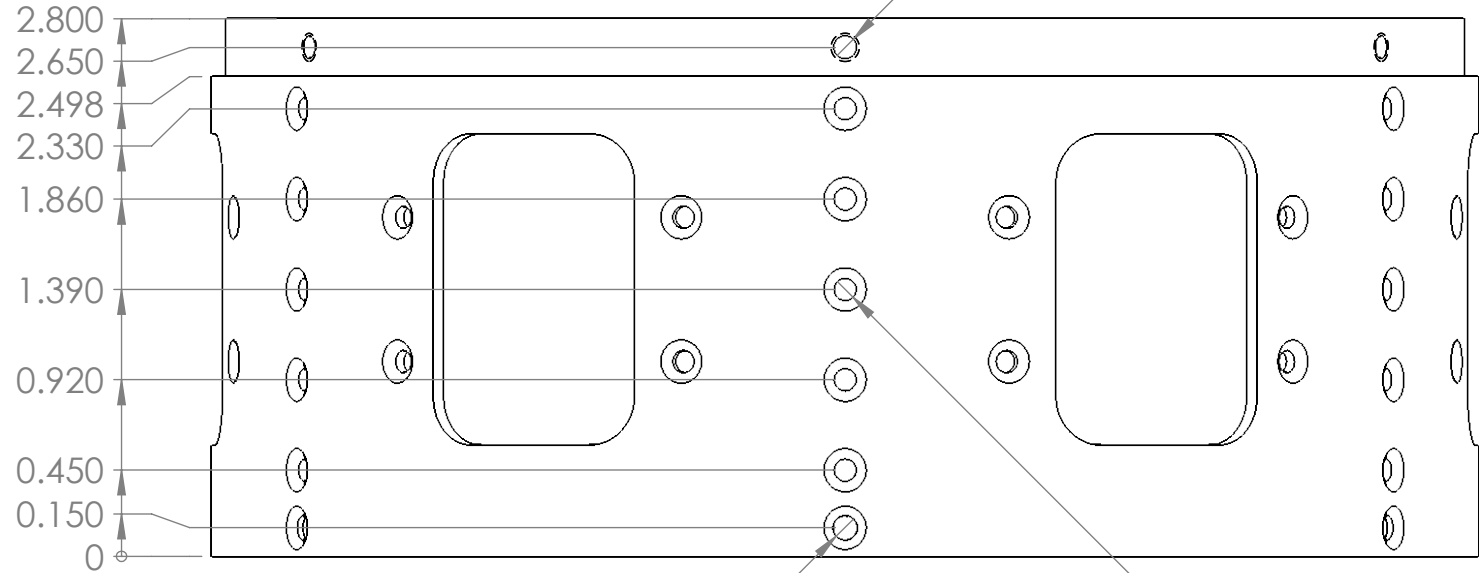

6X ϕ .129 ∇ 1.000
 \surd ϕ .225 X 100°

30X ϕ .116 ∇ 1.000
 \surd ϕ .225 X 100°

SOLIDWORKS Educational Product. For Instructional Use Only

UNLESS OTHERWISE SPECIFIED:
DIMENSIONS ARE IN INCHES
TOLERANCES:
1/32
ANGULAR: MACH \pm BEND \pm
TWO PLACE DECIMAL \pm .01
THREE PLACE DECIMAL \pm .001



MATERIAL
FINISH --
Weight
DO NOT SCALE DRAWING

	NAME	DATE
DRAWN	Joe S.	2/21/2018
CHECKED	--	
ENG APPR.	--	
MFG APPR.	--	

Description:
pillar mounting holes

COMMENTS:
Only holes without
countersinks are
tapped for Helicoils.

DWG. NO.		--
REV	SIZE	SCALE: 1:1
v0.4	A	SHEET 2 OF 4

6

5

4

3

2

1

6

5

4

3

2

1

1.210

(2.800)

(2.498)

2.200

1.765

1.015

0.580

0

22X ϕ .116 ∇ 1.000
 \surd ϕ .225 X 100°

24X R0.250

15°

30°

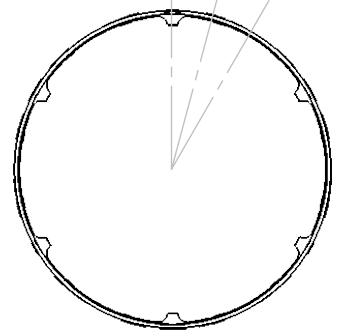

SOLIDWORKS Educational Product. For Instructional Use Only

UNLESS OTHERWISE SPECIFIED:
DIMENSIONS ARE IN INCHES
TOLERANCES:
FRACTIONS: 1/32
ANGULAR: MACH \pm BEND \pm
TWO PLACE DECIMAL \pm .01
THREE PLACE DECIMAL \pm .001

MATERIAL	
FINISH	--
Weight	
DO NOT SCALE DRAWING	

	NAME	DATE
DRAWN	Joe S.	2/21/2018
CHECKED	--	
ENG APPR.	--	
MFG APPR.	--	

Description:
window cutout for
cameras or other pass-
throughs

COMMENTS:

DWG. NO.		--
REV	SIZE	SCALE: 1:1
v0.4	A	SHEET 3 OF 4

6

5

4

3

2

1

D

D

C

C

B

B

A

A

SECTION B-B

SCALE 1:2

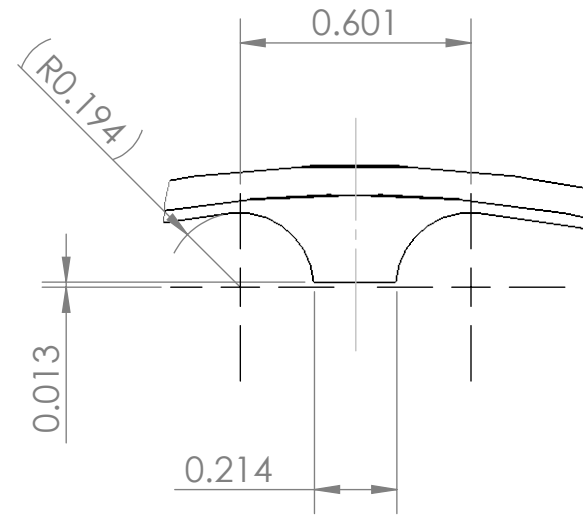
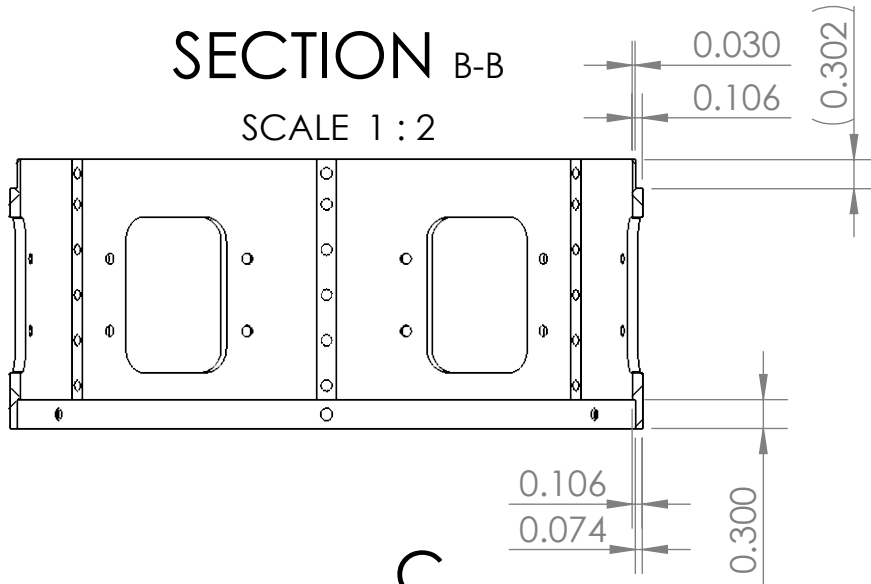

DETAIL C

SCALE 2:1

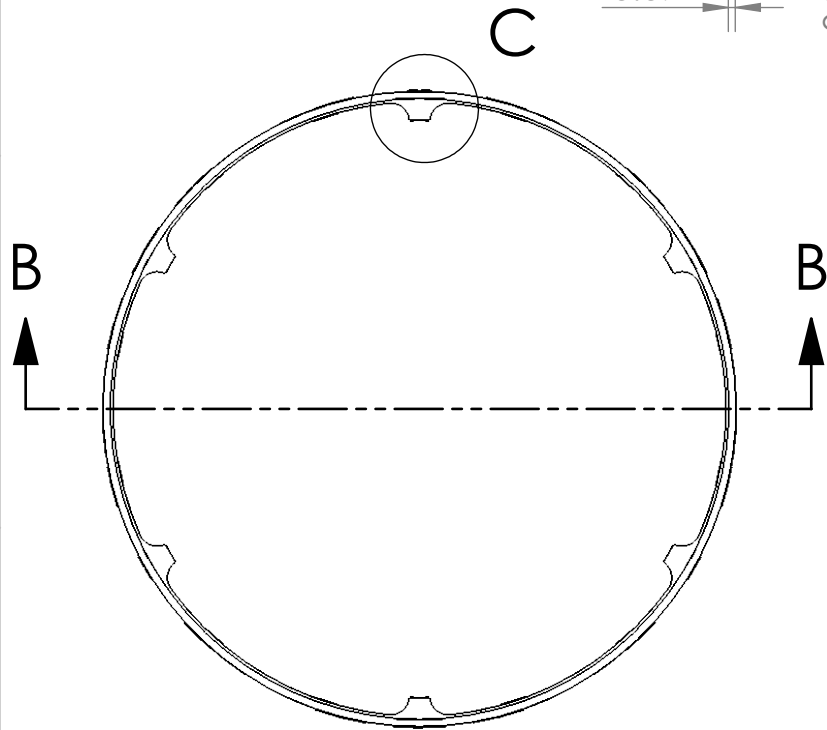

UNLESS OTHERWISE SPECIFIED:
DIMENSIONS ARE IN INCHES
TOLERANCES:
FRACTIONS: 1/32
ANGULAR: MACH ± BEND ±
TWO PLACE DECIMAL ±.01
THREE PLACE DECIMAL ±.001



	NAME	DATE
DRAWN	Joe S.	2/21/2018
CHECKED	--	
ENG APPR.	--	
MFG APPR.	--	

Description:
wall and pillar dimensions

MATERIAL
FINISH
Weight
DO NOT SCALE DRAWING

COMMENTS:

DWG. NO.		--
REV	SIZE	SCALE: 1:1
v0.4	A	SHEET 4 OF 4